



# DIN TXH

*Electronic Dynamometer  
With Remote Control*

## CARATTERISTICHE TECNICHE

## DIMENSIONI IN mm

- Load cell:** total stainless steel construction
- Security overload coefficient:** > 5
- Protection:** IP64 (EN 60529)
- Working temperature:** -5°C ÷ +55°C
- High accuracy:** ± 0,1% of the nominal load
- Transmitter working frequency:** 433,92 Mhz
- Working range:** 50m
- Power supply:** n°1 battery – Type “C” (battery life 200h)
- RXDI02 hand receiver included
- Option:** RX02-PORT hand receiver as an alternative to RXDI02 one

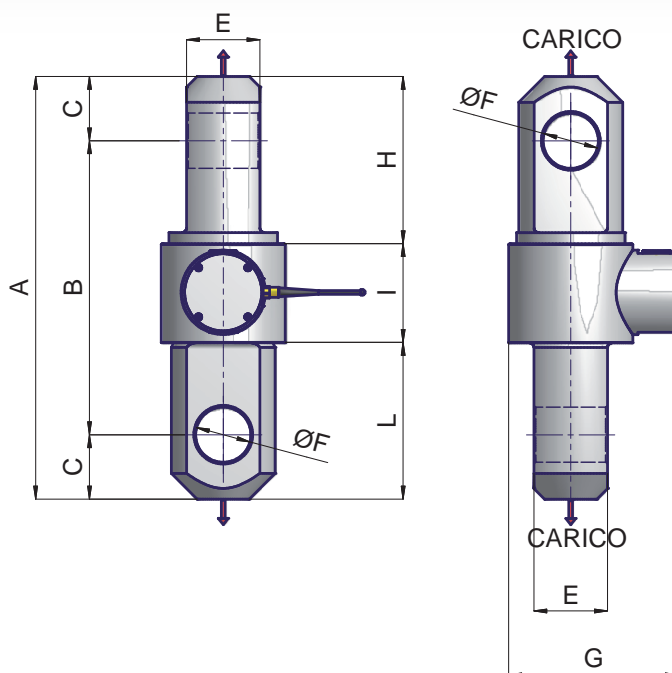

I GRILLI A OMEGA SONO SU RICHIESTA PER TUTTI I MODELLI DI DINAMOMETRO DIN TXH

Portata	Divisione	Dimensioni (mm)										Peso
Capacity	Readability	A	B	C	D	E	F	G	H	I	L	Weight
17 t	10 kg	320	230	45	110	57	44	185	100	120	100	~15 kg
25 t	20 kg	360	250	55	113	72	52	185	132	108	120	~20 kg
35 t	20 kg	460	320	70	113	80	60	185	182	108	170	~27 kg
50 t	50 kg	520	350	85	130	103	72	220	201	134	185	~48 kg
100 t	50 kg	580	380	100	165	123	85	256	210	180	190	~76 kg

