



TSHP / TSHP-A

Lightweight clamp with extra large jaw opening

Application:

- For vertical lifting, handling and transporting of Holland Profile (HP) shipbuilding structures, steel plates and structures
- Turning lathe clamp
- TSHP jaw opening from 0 to 80 mm
- TSHP-A adjustable jaw opening available from: 0 to 155 mm
- TSHP / TSHP-A Working load limit (WLL) 1000 - 1500 kg
- Higher WLL available upon request. Min. WLL is 10% of max. WLL
- Lifting of longer sections should be done with a spreader beam

Note: The plate surface of the material must have a hardness level of max. HRC 37/345 Hb



Features and Benefits:

- Also useful as a "big-jaw" opening clamp
- Standard with 3 pivots for extra powerful clamping force
- Easy handling of workpieces in and out of lathe due to extra small W-dimensions (see illustration)
- Lightweight design for easy handling
- Tough quality heavy duty welded shell body
- Always equipped with a safety mechanism, ensuring the clamp does not slip when lifting force is applied and when load is being lowered
- Clamp is locked in closed as well as open position
- Maintenance-friendly, easy to exchange parts which are available upon request

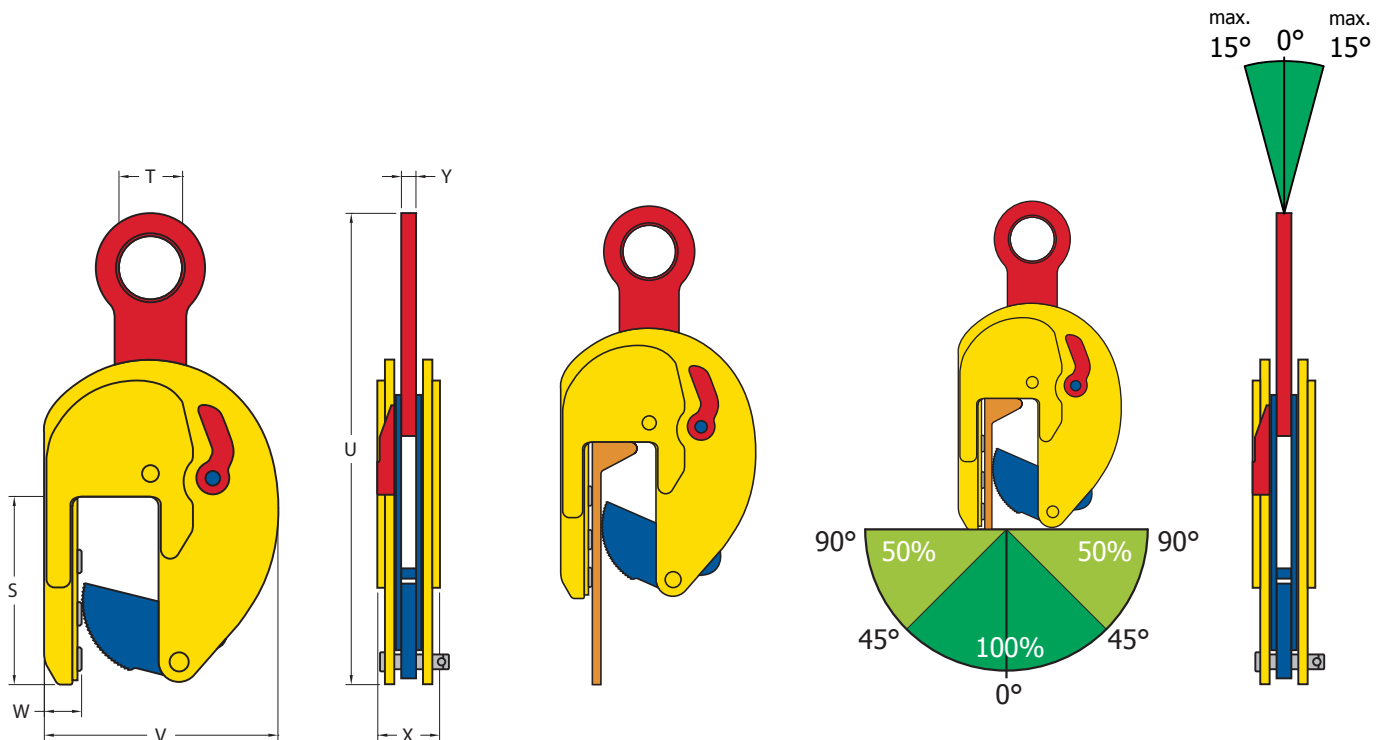

Article Nr.	Type	Capacity (kg/pc)	Jaw opening (R) (mm)	Dimensions in mm							Weight (kg/pc)
				S	T	U	V	W	X	Y	
860110	1 TSHP	1000	0 - 80	207	70	520	257	41	68	16	19
860111	1.5 TSHP	1500	0 - 80	207	70	520	257	41	68	16	19
860155	1.5 TSHP-A	1500	0 - 155	160	70	523	256-333	62	66	16	18